

# Barriera per motociclista - Livello I

Safety barriers for motorcyclists - Level I

Rückhaltesysteme für Motorradfahrer - Level I

Glissières de sécurité pour motocyclistes - Niveau I

Barrera para protección de motociclistas - Nivel I

Sezione A-A'  
Section A-A'

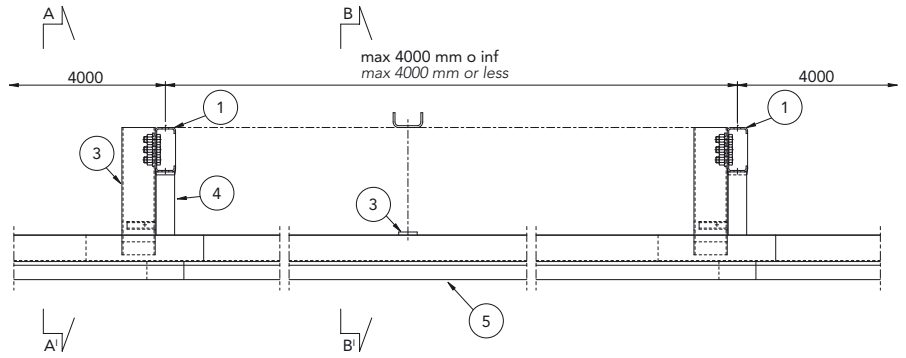
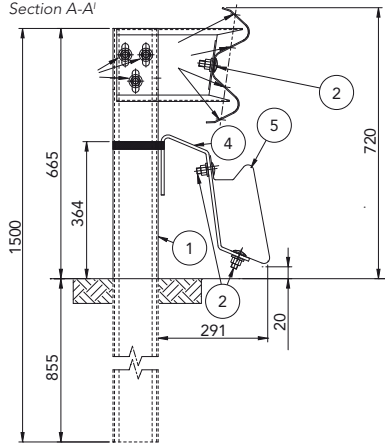

Sezione B-B'  
Section B-B'

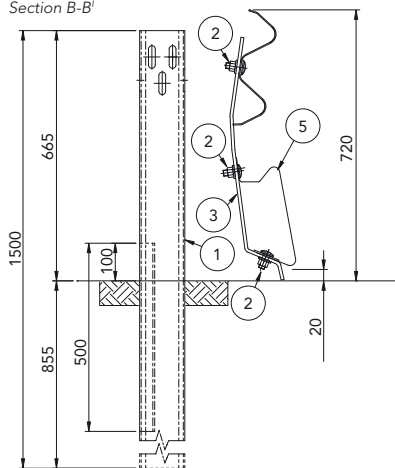

**Rapporti di prova** Crash test reports, Testberichte, Comptes rendus d'essais, Relaciones de pruebas

Test n.	Facility	Test	Type	Barrier length m	Mass kg	Speed km/h	HIC 36	FxN	Fz Traz N	Fz Compr. N	Mcox Nm	Mcoy Flex Nm	Mcoy Estens. Nm
PROVA M028	Aisico	TM 3.60	Mezzeria 30°	16	80	60	298.84	528.77	1515.14	2589.73	27.26	28.14	43.54
PROVA M022	Aisico	TM 1.60	Palo 30°	16	80	60	169.11	337.34	1204.87	2654.33	73.79	20.61	42.27

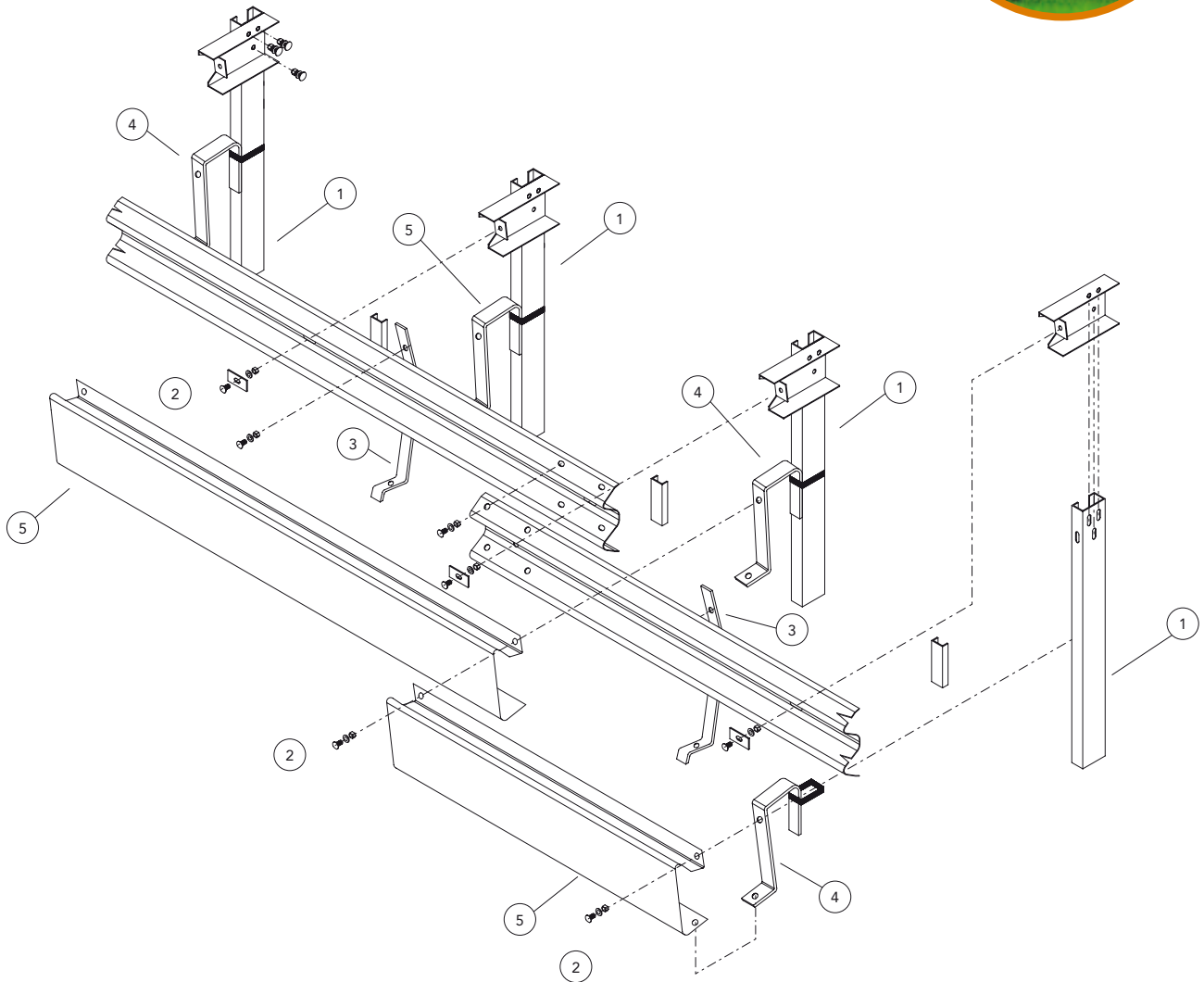
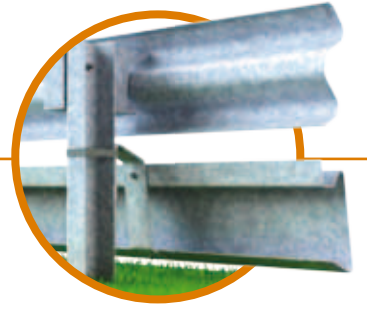

**Componenti Components, Bauteile, Composants, Elementos**

	<b>Descrizione</b> Description		<b>Materiale</b> Material	<b>Codice</b> Code
1	<b>Palo "U"</b> U-post, U-Steher, Poteau en U, Poste "U"	80x40 Th=5 H=500 mm	Corten	59400631
2	<b>Bullone completo</b> Bolt with nut and washer, Schraube komplett, Boulon complet, Tornillo completo con tuerca y arandela	M16x40 mm C=60 nm	Classe 5.8	59800432
3	<b>Staffa sostegno profilo tipo A</b> Support for A-type profile, Haltebügel für Profil Typ A, Étrier support profil type A, Soporte perfil tipo A		S 235 JR	59601663
4	<b>Staffa sostegno profilo tipo B</b> Support for B-type profile, Haltebügel für Profil Typ B, Étrier support profil type B, Soporte perfil tipo B		S 235 JR	59601660
5	<b>Profilo contenimento motociclista</b> Motorcyclist containment profile, Motorradfahrer-Unterfahrschutz, Perfil de retenue motocycliste, Perfil retención motociclista		S 235 JR	59601609